



SERIANA[®]
SEISMIC REINFORCEMENTS
company profile

SERIANA[®]
SEISMIC REINFORCEMENTS

About us
Our services

About us

The company was established in 2013 at the foot of the Val Seriana hills, in the province of Bergamo as Seriana Edilizia S.r.l., to later become Seriana S.p.A. in 2024. .

From its inception, the company focused **on anti-seismic solutions for the prefabricated concrete building industry**, aimed at reducing the vulnerabilities of buildings built prior to 2009, concentrating its efforts and energies within this specific area, and thus establishing itself as a leader in the sector in just a few years.

Today, there are over **80** people dedicated to the anti-seismic sector and more than **1.100** anti-seismic interventions performed for industry, for a total of over **2.600.000** sqm seismically improved.

In support of its presence in Italy, to further increase its performance and support its customers, since 2023 Seriana S.p.A. has chosen to broaden its market by inaugurating **new points**.

Over time, this will allow Seriana to offer its services with extreme capillarity, constantly closer to customers and able to optimise times, guaranteeing the quality standards that distinguish the company, and making the most of experience and precision.

Since 2024, Seriana has been a Benefit Company, a choice that reflects the company's vocation and willingness to make a difference through practices focused on people and the positive influence of its work within the territory and for the environment.



SERIANA[®]
SEISMIC REINFORCEMENTS

Our points

We believe that high professionalism and precise specialisation really make a difference in every area. Having experienced the market in recent years, we have understood how important geographical proximity to the sites of intervention was to provide further added value to the experience that we intend to make available to our Customers every day.

To offer an excellent, more widespread service for our Customers throughout the national territory, we are expanding, thanks to the opening of new points in Italy.



Head Office since 2013
Via Buratti 21
24124 Bergamo (BG)

Point Nord Ovest Italia (Northwestern Italy point) since 2024
Via Vittime di Bologna 3
10024 Moncalieri (TO)

Point Centro Nord Italia (North-Central Italy point) since 2023
Via Nazionale 88/C
52011 Bibbiena (AR)

Certifications & awards



Awards 2026

In 2026, Seriana S.p.A. is once again featured in two major European and national rankings:

Europe's Long Term Growth Champions 2026 (Financial Times & Statista)

- Among the 300 European companies ranked for long-term growth (2014–2024)
- 4th place in Europe in the Construction & Engineering category

Leaders of Growth 2026 (Il Sole 24 Ore & Statista)

- Ranked for the 5th consecutive year among the 500 Italian companies with the highest revenue growth in the 2021–2024 period

Our departments

We have always believed that Seriana's true value is determined by its people.

Over the years, the company organisation has developed into several specialised departments that work in tune to achieve results and objectives.



DISCOVER OUR PROFESSIONALS



Operation process

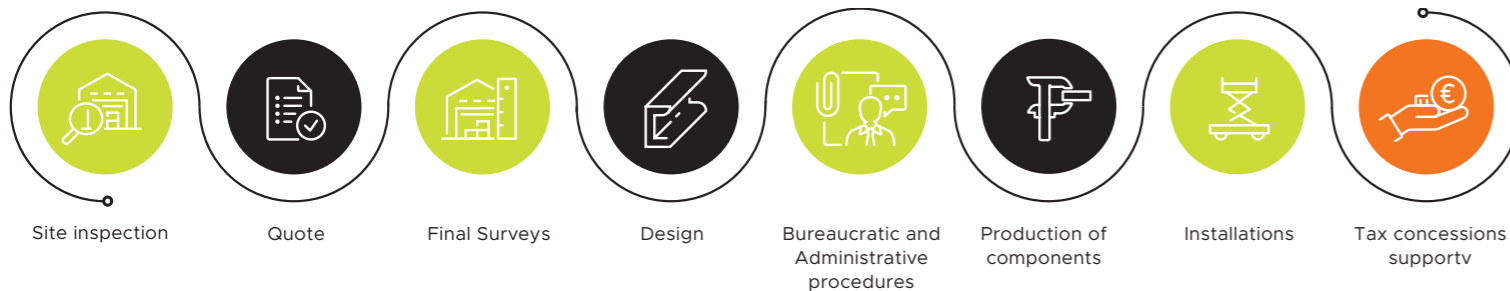

Our essezero method

Through our work in companies, we have come to appreciate just how essential it is, for our Customers, that we manage to design and develop an **intelligent system** so that the benefits of the earthquake strengthening work would be immediately evident without causing **any disruption or inconvenience**.

This goal has led to our purpose-developed ESSEZERO, a working method that is:

multidisciplinary proven performant



The Essezero keypoints



Continuity, without any inconvenience to the customer's corporate activity



Bypass industrial layouts



Work 24/7



Work in total **safety**



v ee



Work methods with **'ZERO DUST'** to protect the most sensitive environments

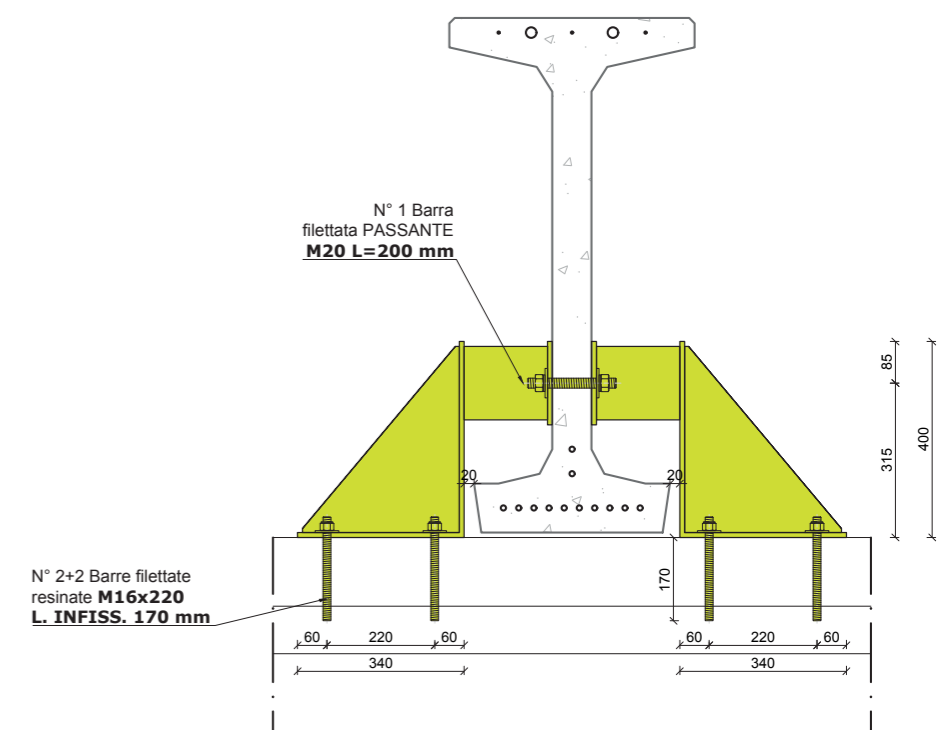
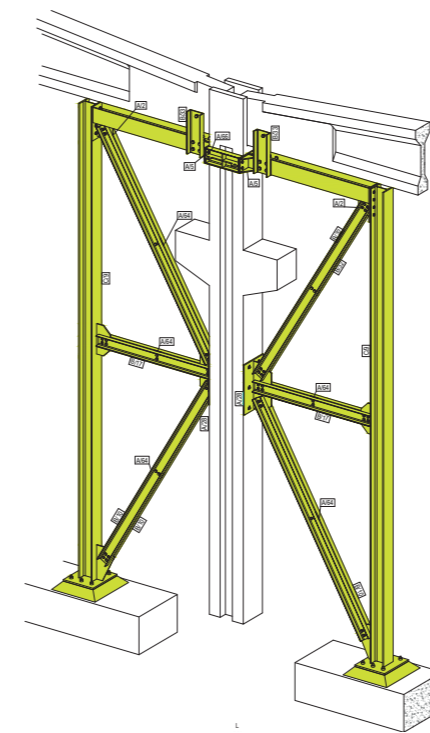
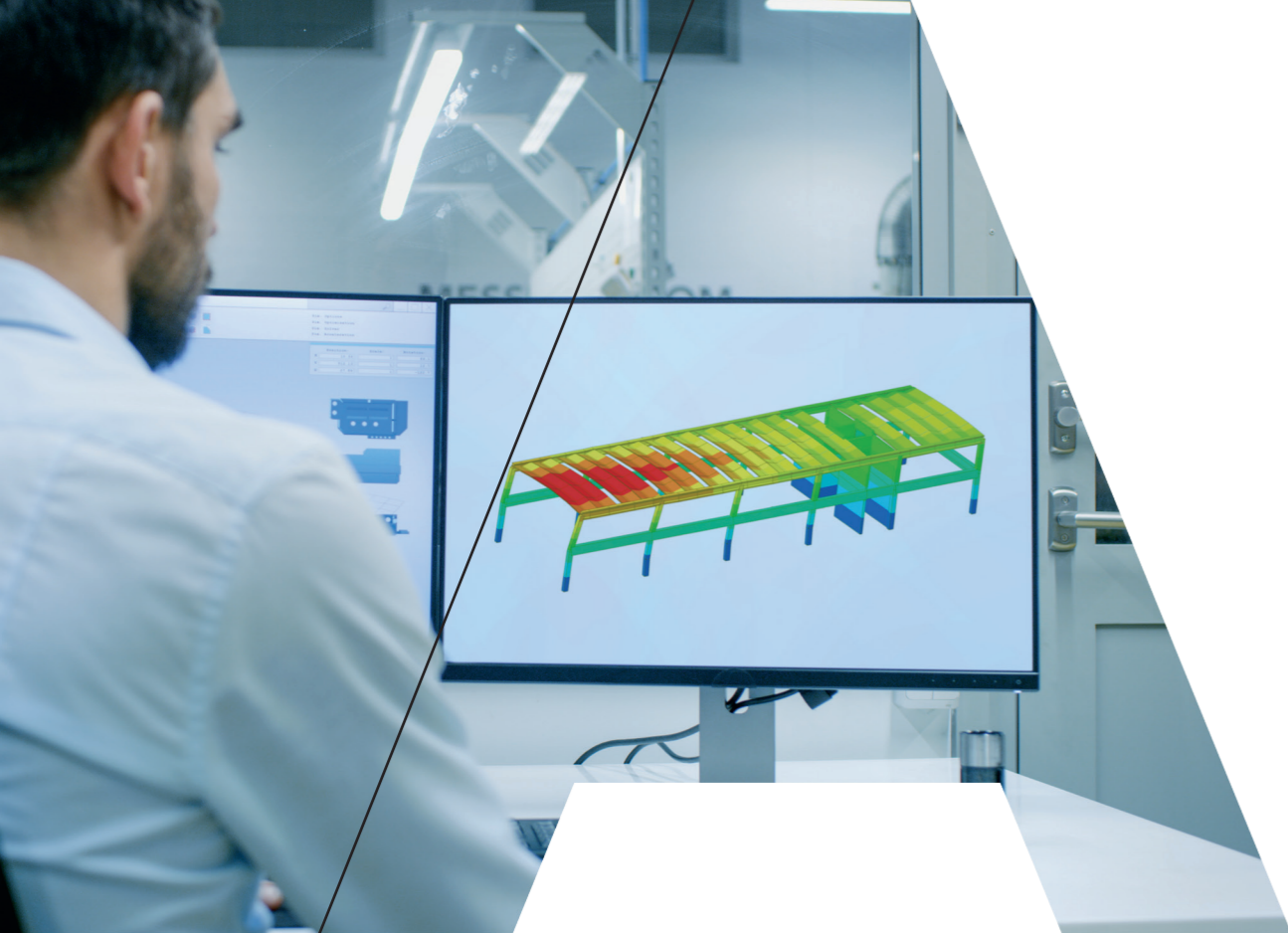

Planning ad hoc

Thanks to SE LAB, an engineering design company with origins in symbiosis with Seriana, our services are customised starting from design through latest-generation software and technologies in modelling.

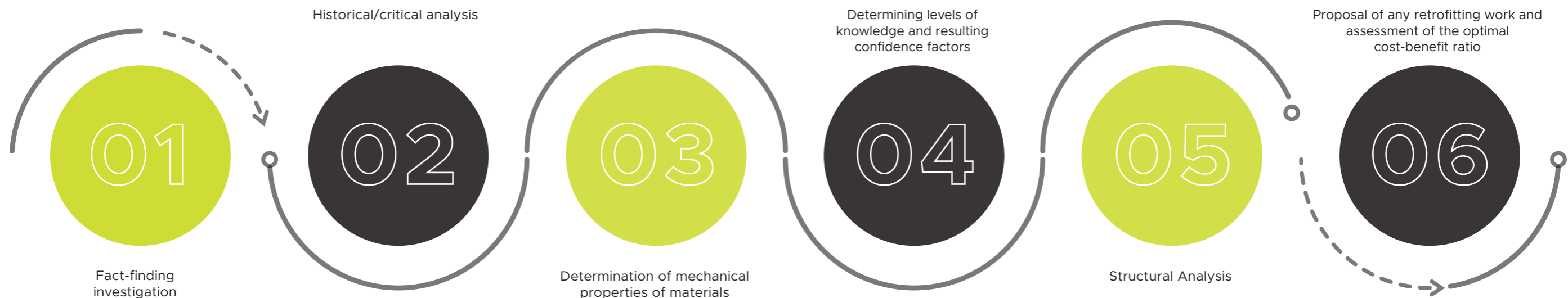
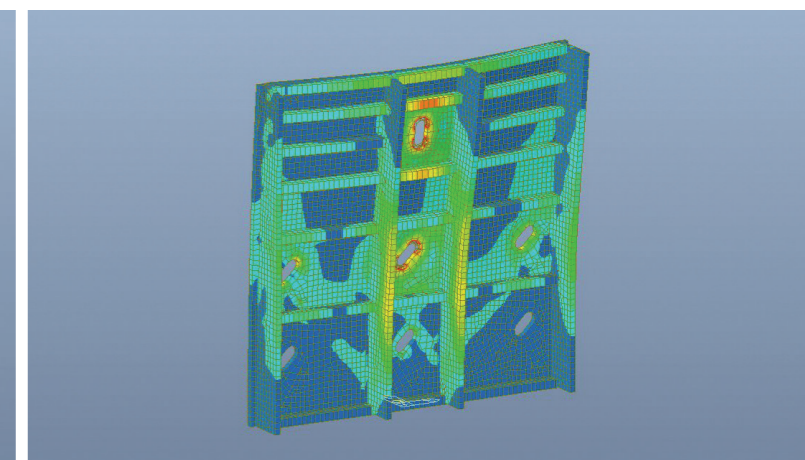
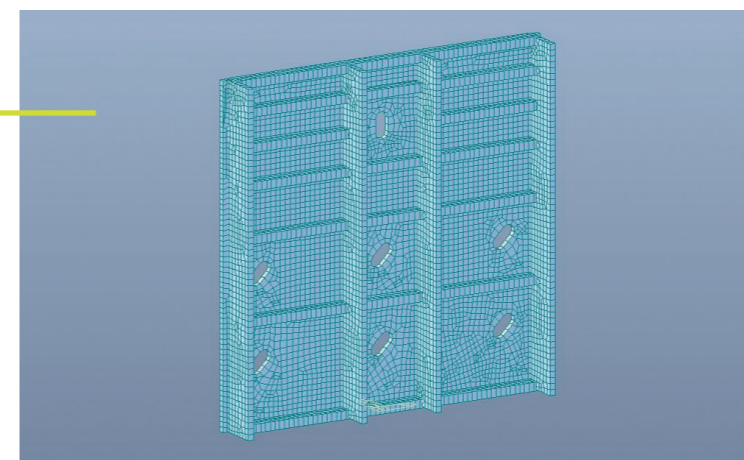

Our anti-seismic devices

Primary beams connections

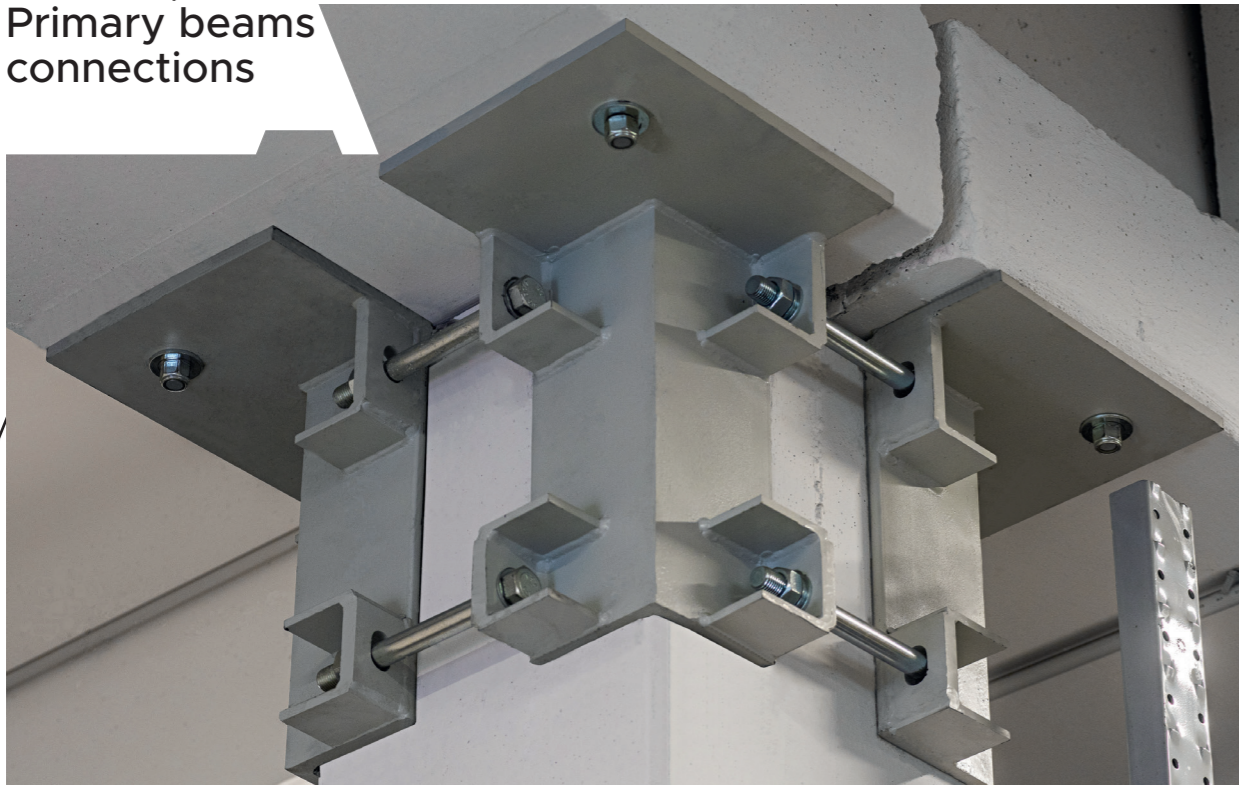

Roof beam connections



Examples of roof-beam constraint systems



PHOTOGRAPHIC PORTFOLIO OF CREATIONS



Examples of beam-pillar constraint systems

Secondary elements connections

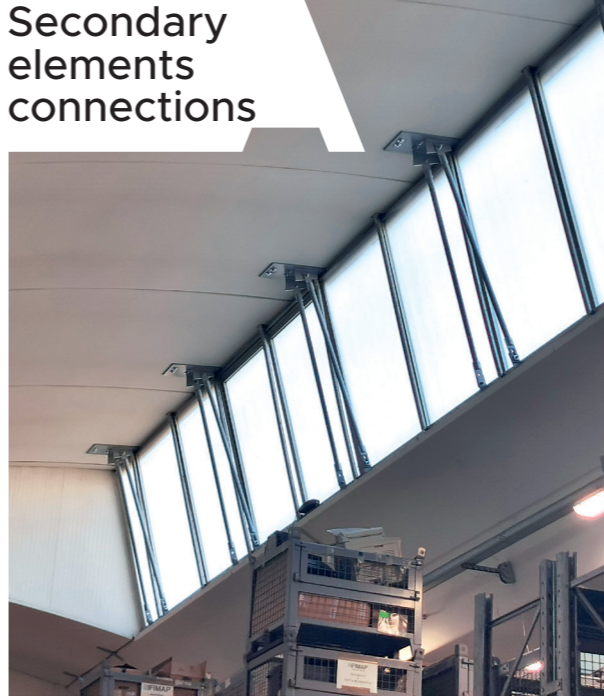

Examples of secondary elements constraint systems

Precast panel connections



Examples of panel restraint systems

Upgrade work



Connections from the outside of the building



Examples of externally installed constraint systems



Examples of systems installed in seismic improvement and retrofitting

Need more information?

WWW.SERIANASPA.IT
INFO@SERIANASPA.IT
TEL. +39 035 659 1371



SERIANA[®]
SEISMIC REINFORCEMENTS

www.serianaspa.it